

Spec Master HPU60 Series

6.0 Purity Nickel Plated Brass Barstock Integrated Outlet Point



The Spec Master HPU60 Series diaphragm integrated outlet points are designed for secondary pressure gas control of non-corrosive or toxic, high purity gases up to grade 6.0 purity (99.9999%), on gas distribution systems at the point of user control.

- **HPU6001** Series | Wall Mounting, 1/4 NPT Female Inlet, FKM Seal
- **HPU6002** Series | Wall Mounting, 1/4 NPT Female Inlet, EPDM Seal
- **HPU6011** Series | Bench Mounting, 1/4 NPT Female Inlet, FKM Seal
- **HPU6012** Series | Bench Mounting, 1/4 NPT Female Inlet, EPDM Seal
- **HPU6021** Series | Wall Mounting G3/8 Female Inlet, FKM Seal
- **HPU6022** Series | Wall Mounting G3/8 Female Inlet, EPDM Seal



FLOW PERFORMANCE

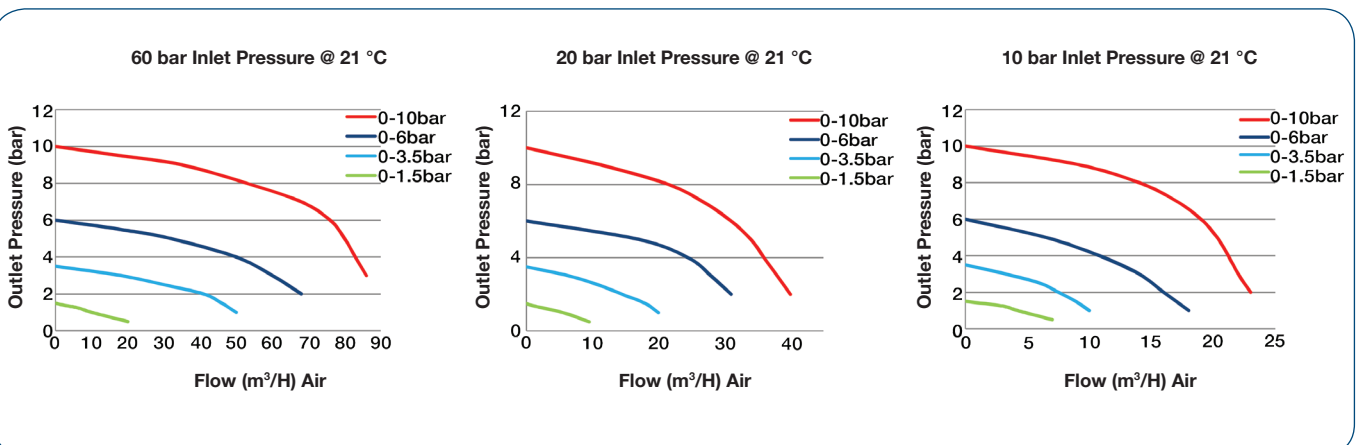

FEATURES

- Ergonomic compact design
- Integrated process pressure gauge and shut-off diaphragm isolation valve
- Encapsulated seat design
- Range of wall and bench mounting options
- Fully interchangeable within existing installations
- Gas identification label options to ISO13792



MATERIAL

▪ Body	Nickel Plated Brass Barstock
▪ Bonnet	Nickel Plated Brass
▪ Bonnet Seal	PTFE
▪ Diaphragm	316L Stainless Steel
▪ Valve Seat	PCTFE
▪ Seal	FKM / EPDM
▪ Filter	10 Micron 316L Stainless Steel



SPECIFICATION

▪ Maximum Inlet Pressure	60 bar (870 PSI)
▪ Delivery Pressure Range	1.5 bar (22 PSI) 3.5 bar (50 PSI) 6 bar (90 PSI) 10 bar (150 PSI)
▪ Inlet Ports	1/4" NPT Female G3/8 R/H Female
▪ Outlet Ports	1/4" NPT Female
▪ Temperature Range	-20° C to +60° C (-4° F to +140° F)
▪ Weight	0.55 kg (1.21 lb) maximum

Outlet Point – Wall Mount Bracket Kit – RAC36225

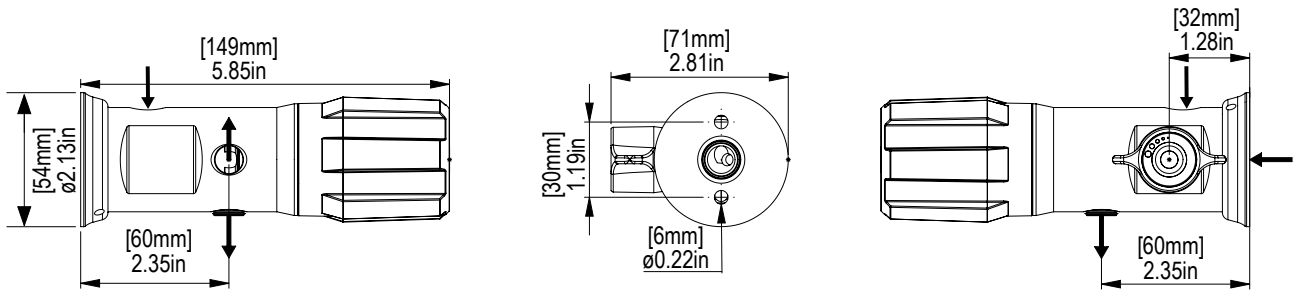

Outlet Point – Wall Mount

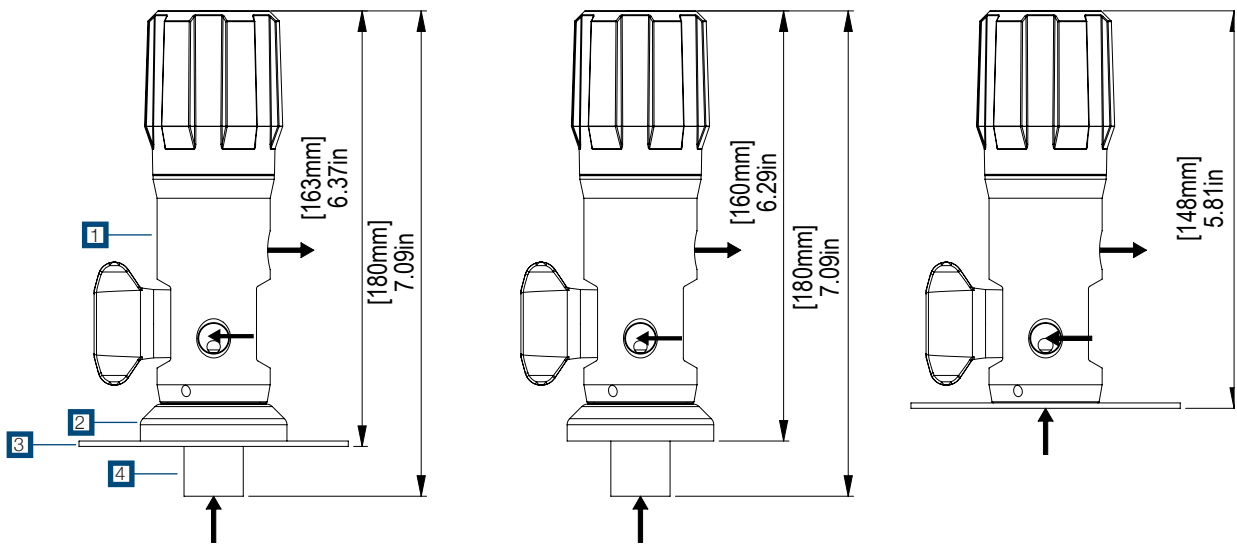

- 1** Outlet Point
- 2** Wall Cover RAC36222
- 3** Wall Plate
- 4** Wall Adapter

Outlet Point – Bench Mount – RAC36092

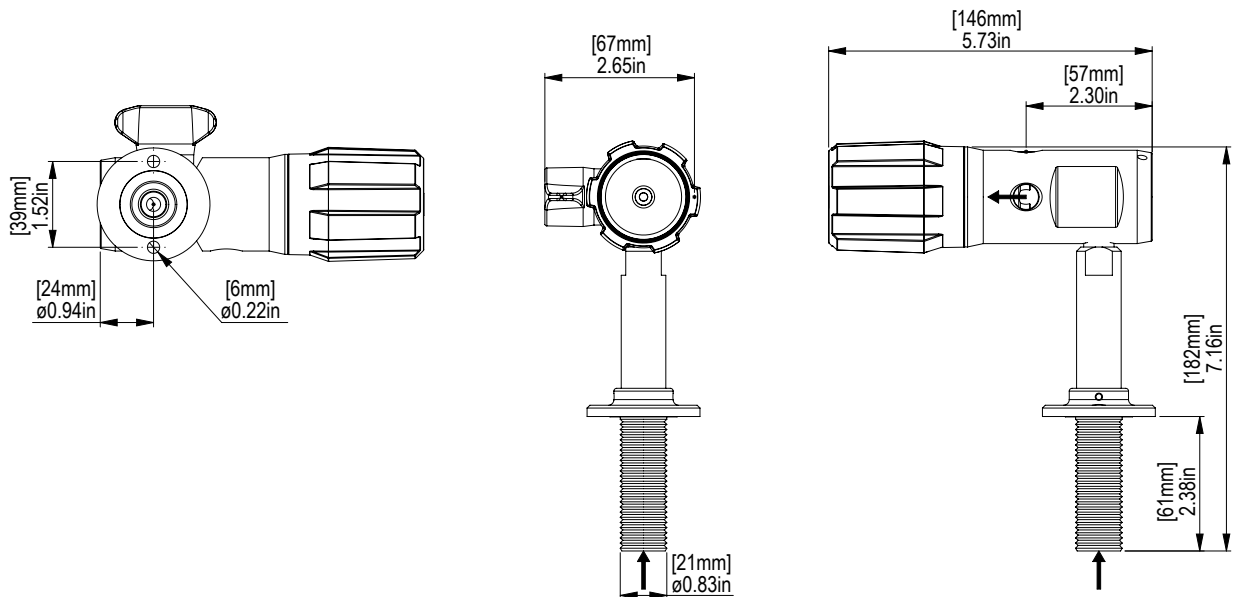

Wall Adapter – 8mm Tube
RSP00237

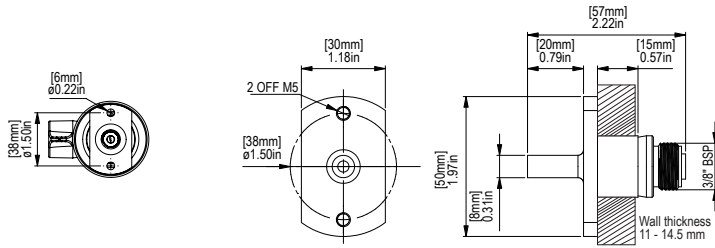

Wall Adapter – 1/4 NPT Female Inlet
RSP00238

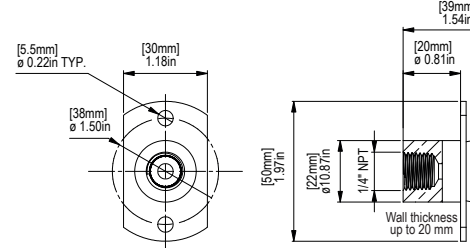

Wall Plate for Wall Adapter

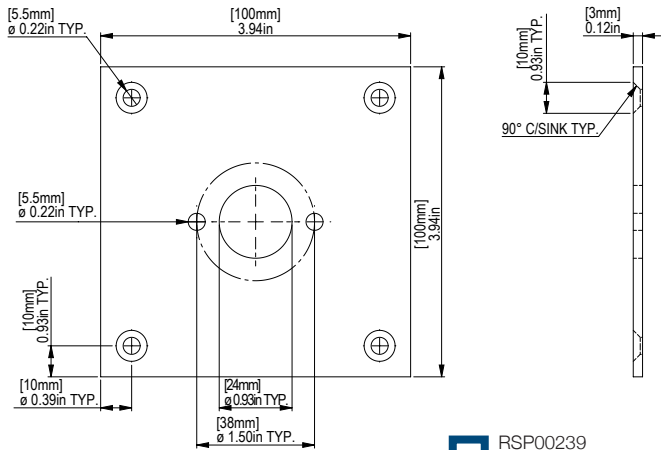

1 RSP00239

Wall Plate for 1/4 NPT Female

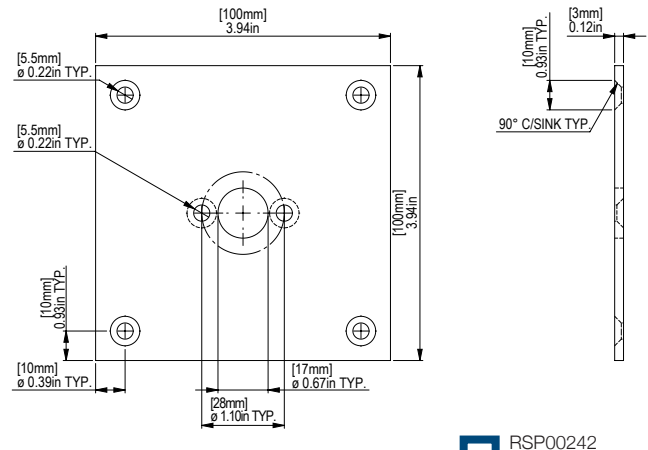

1 RSP00242

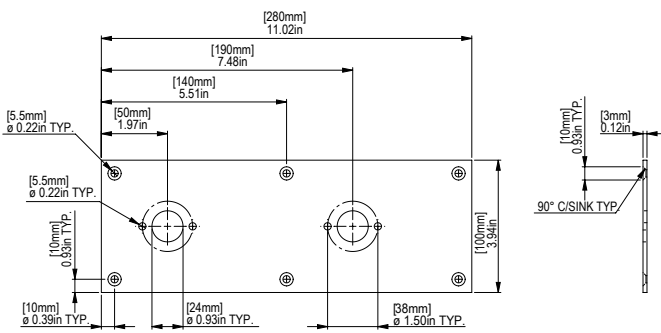

2 RSP00240

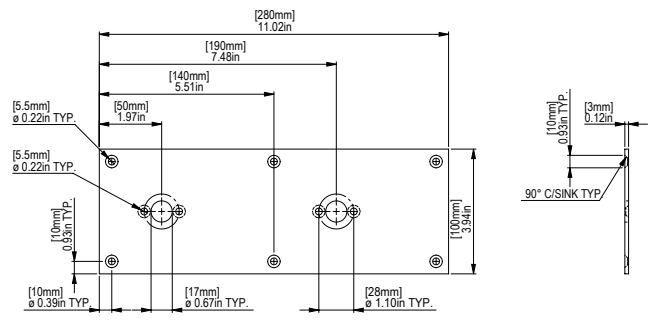

2 RSP00243

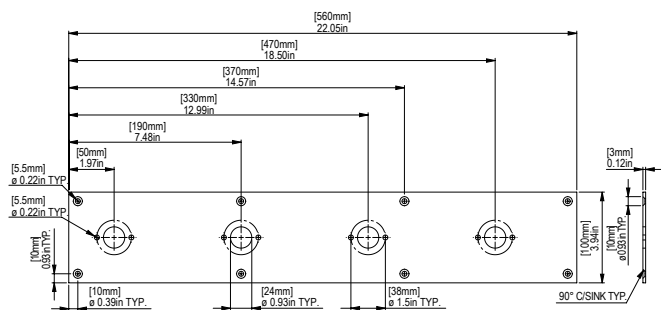

4 RSP00241

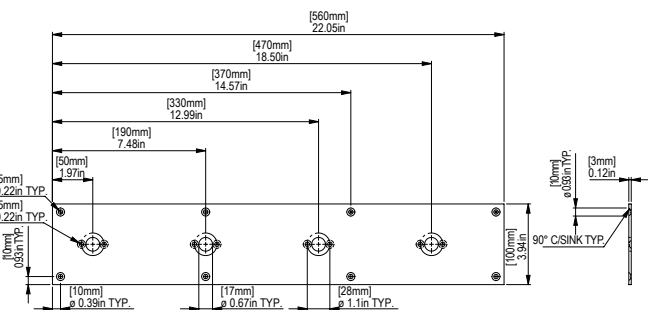

4 RSP00244

MODEL NO. SELECTOR GUIDE

Example for a Model No. for HPU60 Series

Product Type	Inlet Pressure Bar [PSI]	Outlet Pressure bar [PSI]	Inlet Connection	Outlet Connection	Gas Identification Label **	Options
HPU6001	02 60 bar [870]	02 0 to 1.5 [22]	000 1/4 NPT Female	00 1/4 NPT Female	00 No Gas Identification Label	A No Option Selected
HPU6002		03 0 to 3.5 [50]	001 1/8 SST Compression	01 1/8 SST Compression	01 Natural Gas (G)	G Helium Test Certificate
HPU6011		04 0 to 6 [90]	002 1/4 SST Compression	02 1/4 SST Compression	02 Propane / Butane	K Certificate of Conformity (CoC)
HPU6012		05 0 to 10 [150]	065 3/8 SST Compression	65 3/8 SST Compression	03 Methane (CH4)	P Calibration / Pressure Test Certificate
HPU6021			067 1/2 SST Compression	67 1/2 SST Compression	04 Propane (C3H8)	X Special Instruction
HPU6022			003 6 mm SST Compression	03 6 mm SST Compression	05 Butane (C4H10)	
			091 8 mm SST Compression	91 8 mm SST Compression	06 Ethane (C2H4)	
			066 10 mm SST Compression	66 10 mm SST Compression	07 Propene (C3H6)	
			068 12 mm SST Compression	68 12 mm SST Compression	10 Argon / Methane (Ar / CH4)	
			004 1/4 NPT Male	04 1/4 NPT Male	11 Hydrogen / Nitrogen (H2 / N2)	
			100 G3/8 R/H Female *		12 Hydrogen (H2)	
					14 Hydrogen / Helium (H2 / He)	
					15 Deuterium (D2)	
					16 Nitrogen (N2)	
					17 Nitrous Oxide (N2O)	
					18 Synthetic Air 80/20 (SA)	
					19 Compressed Air (CA)	
					20 Oxygen (O2)	
					21 Carbon Dioxide (CO2)	
					22 Regulated Air (RA)	
					23 Breathing Air (BA)	
					24 Carbogen (CO2 / O2)	
					25 Krypton (Kr)	
					26 Xenon (Xe)	
					27 Neon (Ne)	
					28 Argon (Ar)	
					29 Helium (He)	

* Only available inlet option when ordering G3/8 female rear inlet variant for wall mounting adapter